

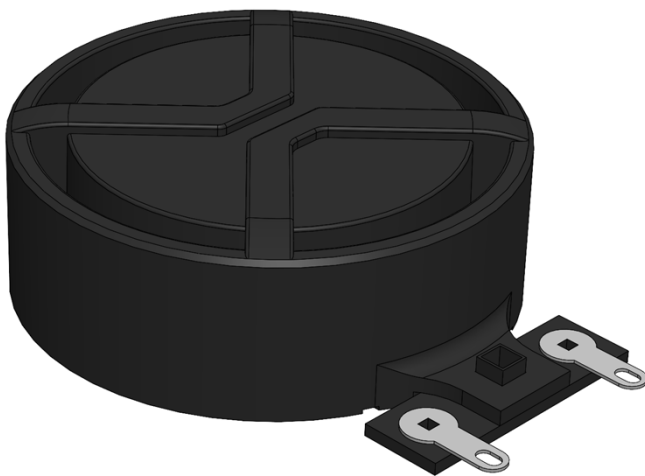

XTREME SERIES

Xtreme Audio Performance
at an Unbeatable Price!

XT25-4 SPECIFICATIONS



- > Xtreme Upper Frequency Limit
- > Xtreme Precise and Powerful
- > Xtreme Low Distortion
- > Xtreme Reliable
- > Designed in Germany

XT25-4 SPECIFICATIONS

Electrical and Mechanical Properties

Rms Noise Test [W]	15
Long-term Max Power [W]	30
Frequency Range [Hz] ¹	40Hz – 19kHz
Nominal Impedance [Ohm]	4
DC Resistance [Ohm]	3.79
Le [mH] Re2 [Ohm] Le2 [mH]	0.07 2.87 0.05
Kms [N/mm]	6.05
Cms [mm/N]	0.17
Bl [N/A]	3.73
Motor Efficiency Factor β [dB] ²	5.65
Linear Xmax - IEC 60268 [mm]	± 1.4
Mechanical Xmax [mm]	± 3.0

Position Related Properties ³	Magnet	Coil
Fs [Hz]	44.4	306
Mms [g]	75.2	1.58
Rms [Kg/s]	0.85	0.09
Qts	4.63	0.88
Qms	24.8	18.5
Qes	5.7	0.93

Physical Properties

Total Weight [g]	76.8
Outer Diameter [mm]	46.8
Total Height [mm]	21.5
Voice Coil Diameter [mm]	25
Voice Coil Layers	2

- (1) The final frequency range is dependent on the panel properties
 (2) $10\log(\beta)$ with $\beta = Bl^2/Re$ [ref: 1Kg/s]
 (3) Exciters have two degrees of freedom - TSP measured by fixing one
 * On-axis anechoic measurement 1m/2.00V [1/3rd octave smoothing]
 3mm acrylic panel with A=0.3m² and R=2 - fixed edges - open back
 XT25-4 positioned at 35% | 50% - converted from 4pi to 2pi (+6dB)

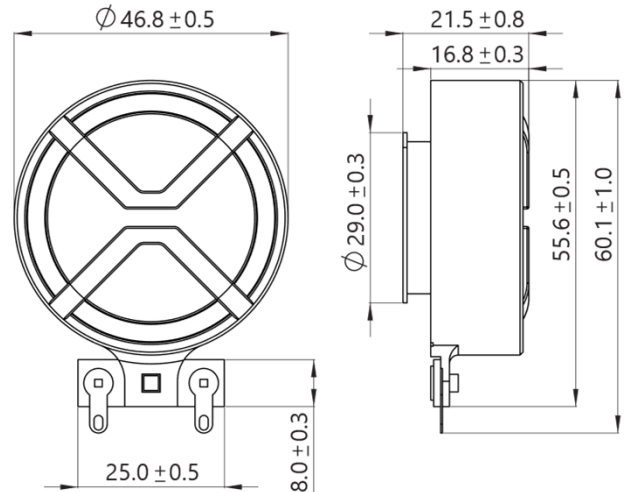

Distortion Relevant Properties

At higher amplitudes, exciters generate nonlinear distortions primarily from $Bl(x)$ and $Kms(x)$. The Xtreme Series is optimized to generate low harmonic and intermodulation distortions.

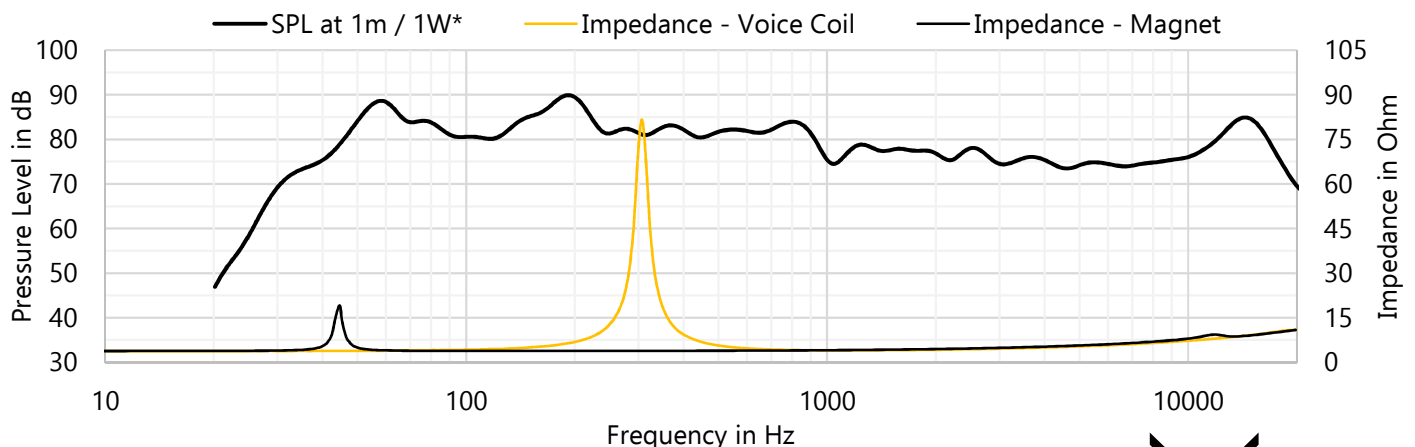
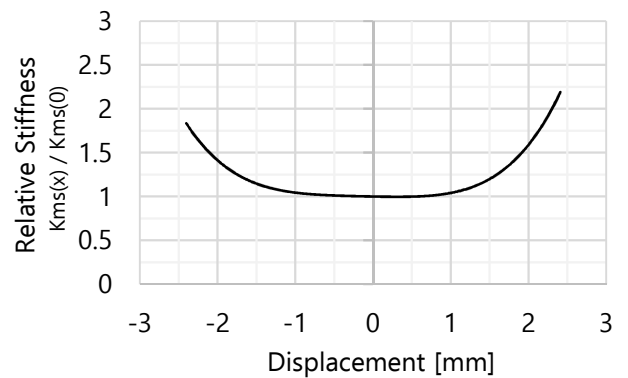
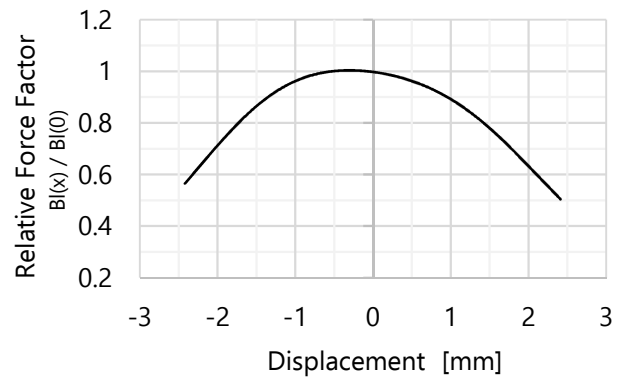

XTREME SERIES

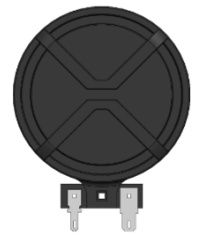

XT19-4

XT25-4

XT32-4

XTB40-4

	Xtreme Slim	Xtreme Highs	Xtreme All-round	Xtreme Bass
Long-term Max Power [W]	20	30	40	160
Frequency Range [Hz]	75Hz – 20kHz	40Hz – 19kHz	35Hz – 17kHz	25Hz – 1kHz
Fs Magnet [Hz]	83.8	44.4	40.5	28.9
Motor Efficiency Factor β [dB]	2.44	5.88	6.97	14.9
Linear Xmax [mm]	± 1.0	± 1.4	± 1.6	± 2.5
Mechanical Xmax [mm]	± 2.4	± 3.0	± 3.5	± 5.0
Total Height [mm]	14.0	21.5	24.8	31.0
Outer Diameter [mm]	36.3	46.8	54.5	65.0
Total Weight [g]	30.0	79.3	133	319

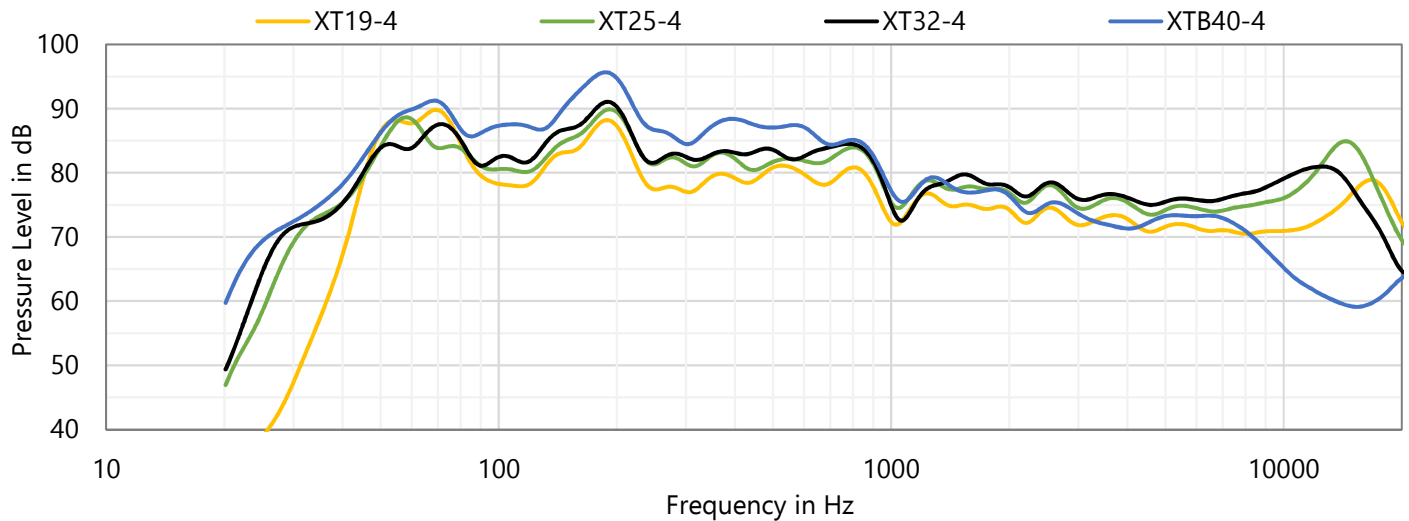

h=14.0mm



h=21.5mm



h=24.8mm



h=31.0mm



d=36.3mm



d=46.8mm



d=54.5mm



d=65.0mm